

Eliminator TrackTM

Versatility at Work

Installation Instructions

Eliminator Track™

Important Things to know

- Use the screws, provided in each box, to attach Eliminator Track™ to the ceiling grid
- Understand the “Basic Cut”. You will use this cut at:
 - The first piece of track in a run
 - Corners
 - T-intersections
 - Doorways
 - Endwalls
- When properly laid out, all pre-punched holes in Eliminator Track™ will be in the center of the 2x4 ceiling grid, drastically reducing the time needed to stand a wall
- Tools commonly needed:
 - Screw gun
 - #2 Phillips head driver
 - Aviation snips
 - 6-12, 1” spring clamps
 - Tape measure
 - Combination square

Basic Cut

The **Basic Cut** is used during installation at: **a.)** the beginning of a wall run, **b.)** at corners, **c.)** at T-intersections, **d.)** at doorways and **e.)** at endwalls

The purpose of the Basic Cut is to allow room for the stud to slide through the opening when the track needs to be modified in the wall conditions listed above so that the stud can be placed in the proper position to make a strong wall detail.

All measuring and cutting takes place on the floor before installing track and studs

Eliminator Track™

Basic Cut (continued)

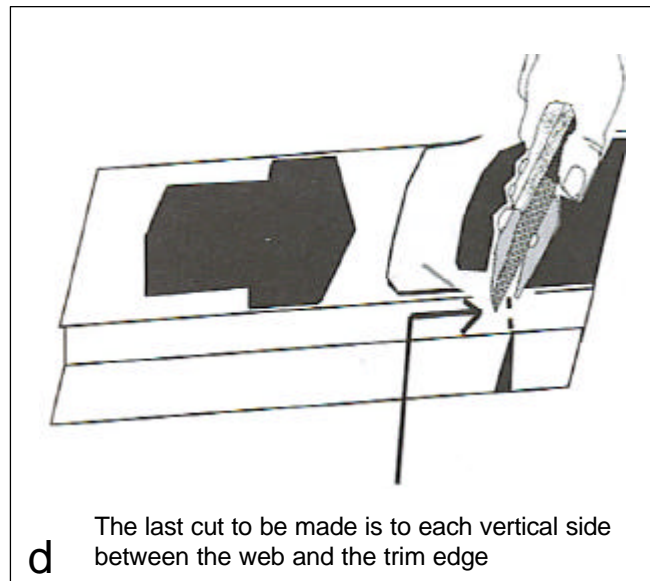
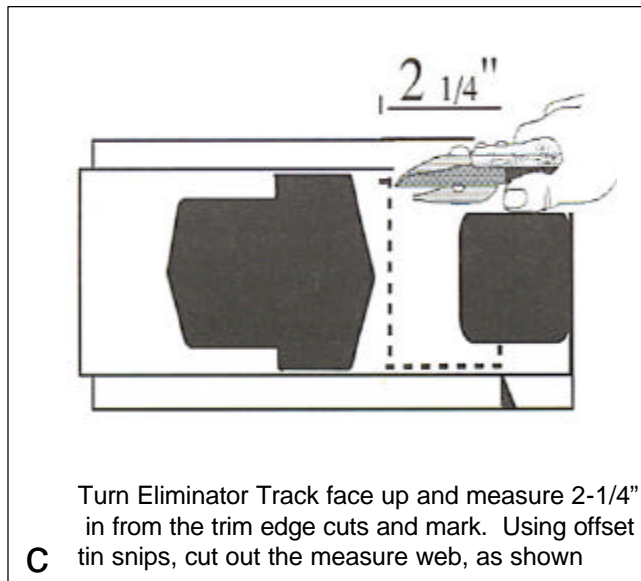
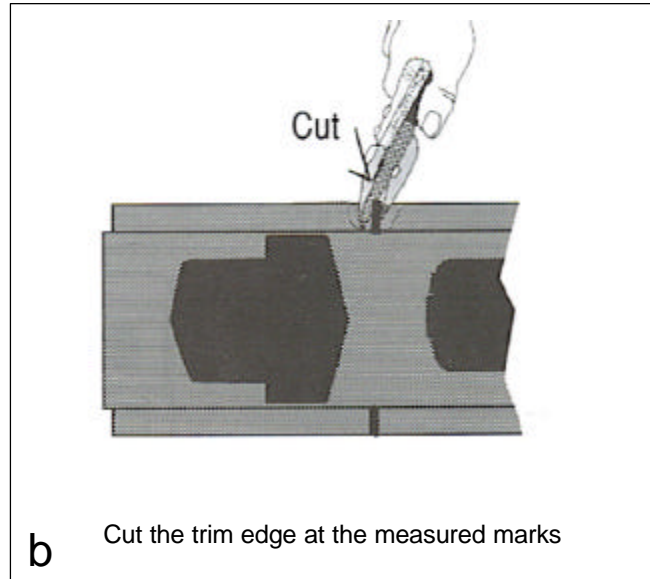
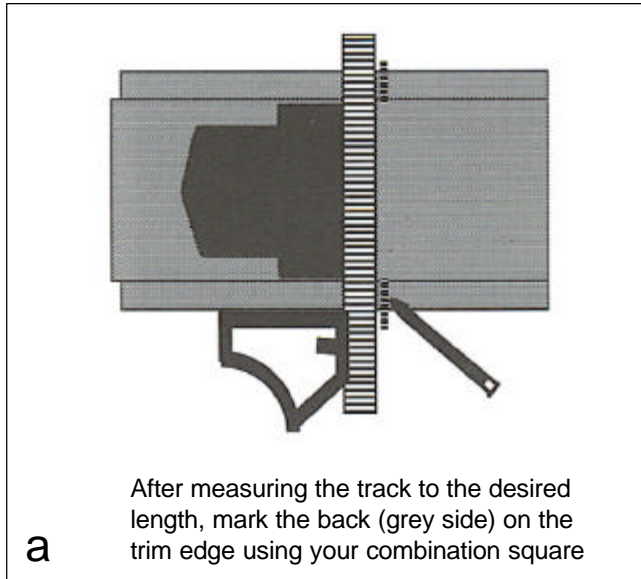

Eliminator Track™

Installation Instructions

Installing the first piece of track in wall run

It is very rare that a full 8' or 12' length of Eliminator Track™ is used for the first piece of track attached to the ceiling grid. Properly installed, Eliminator Track™ should end at the midpoint of the T-grid. This way, all joints are securely fastened to the ceiling grid and the use of splice plates is greatly reduced or eliminated. Taking some time at the beginning of a wall run to measure will speed up the installation and improve the quality of the job.

Measure from the starting point to the middle of the T-grid closest to the end of the 8' or 12' length of Eliminator Track. **DO NOT cut the Eliminator Track™ at the end of the piece of track.** You will want a factory finished end to fall on the T-grid. So, measure from the end of the length of track back towards the starting end. Cut to length. The cut end will be used at your starting point. Make the **Basic Cut**, as described above, Measure and mark the T-grid for placement of Eliminator Track™, clamp Eliminator Track™ in place with 1" clamps and attach to each cross piece of the T-grid using the 7/16" pan head screws provided in each box. Using this method, all pre-punched holes will fall in the center of the ceiling grid.

Continuing the wall run with Eliminator Track™

To continue the wall run, simply butt the next length of track to the prior length, clamp and attach with screws as described.

It is important that all pre-punched openings run in the same direction as the piece(s) before.

See photos for examples.



Eliminator Track™

Building a 90° or a 135° corner

When approaching a corner, measure Eliminator Track™ to the desired length and cut. Attach the cut length of Eliminator Track™ to the ceiling grid using the 7/16" pan head screws included in each box. Make the **Basic Cut**, as shown in Fig. 5.



The corner is the same as the starting point described previously. Measure to the farthest T-grid where Eliminator Track™ can be attached. Measure this distance back to the starting end of the track. Cut to length and make a **Basic Cut**, as shown. There will be two Basic Cuts at each corner. Clamp the pieces of track together (Fig. 6). Verify that the angle is correct using the factory corners (Fig. 7 & 8). You can also use the "3-4-5" method to determine the correct angle for 90° corners

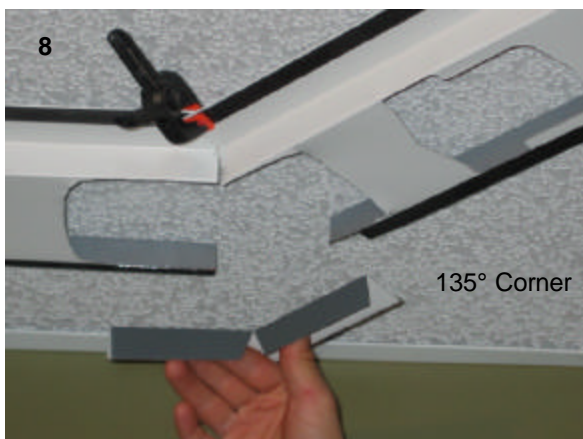

Continued on next page

Eliminator Track™

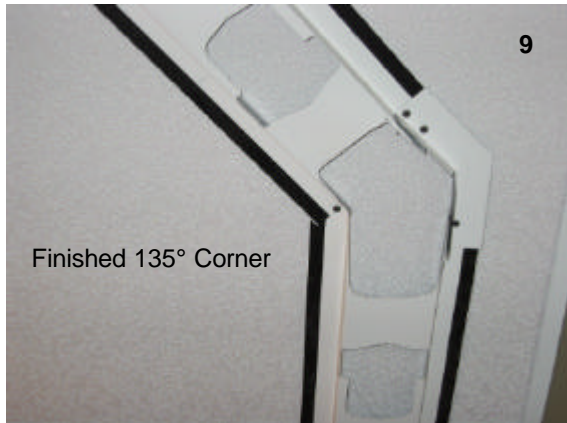

Attach Eliminator Track™ to all T-grids and attach the corner piece, using the same 7/16" screws provided in each box. (Fig. 9 & 10)

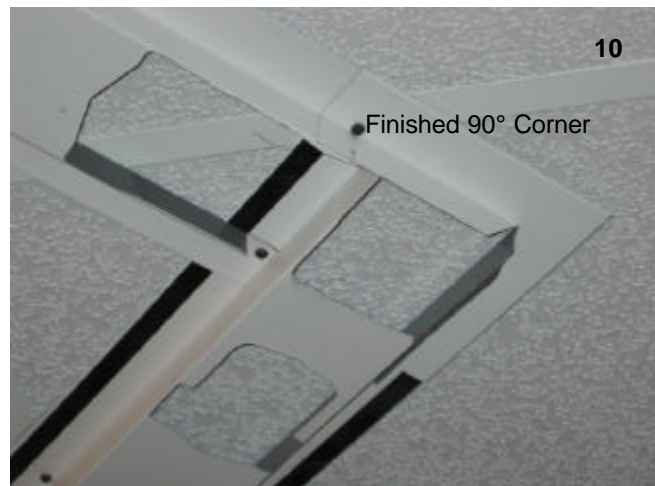

Notch Detail

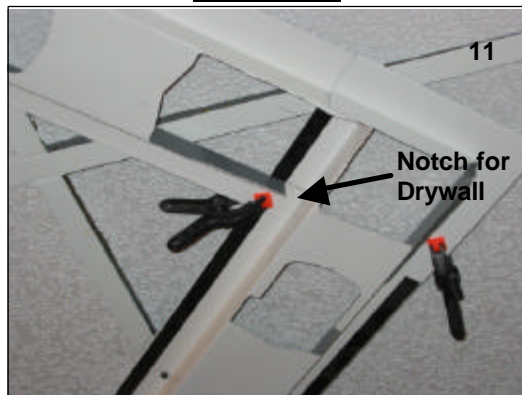

To create a strong wall corner when the wall panel is installed, it is recommended that you notch Eliminator Track™ to allow the drywall or panel to extend beyond the inside of the corner. Once attached to the studs, this detail creates a very strong wall detail. See Fig. 11 for an example. Cut the notch, with Aviation snips, prior to forming the corner.

Notch Cut



Eliminator Track™

Endcap Detail

Building an Endcap

When approaching the end of a wall run that does not terminate into another wall, you will be using the endcap detail. Measure Eliminator Track™ to the desired length and cut. Make the **Basic Cut**, as shown in Fig. 12. Attach the cut length of Eliminator Track™ to the ceiling grid using the 7/16" pan head screws included in each box.

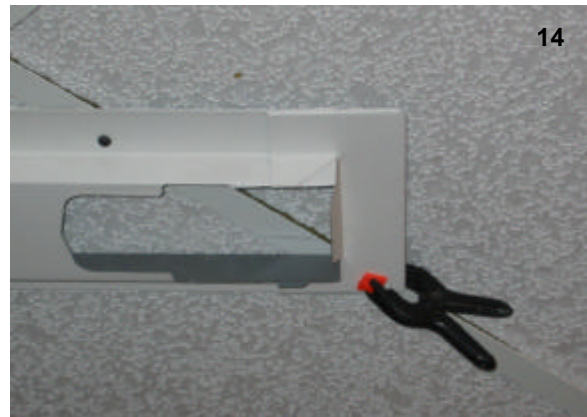

Eliminator Track™

T-Intersections



When approaching the end of a wall run that terminates into another wall, you will be using the simple T-intersection detail. Measure Eliminator Track™ to the desired length and cut. Make the **Basic Cut**. Attach the cut length of Eliminator Track™ to the ceiling grid using the 7/16" pan head screws included in each box. See Fig. 16, 17 & 18 for an example. **IMPORTANT** – You will notch Eliminator Track™ at the T-intersection. As with the corner detail, this will allow you to build a stronger wall (see Fig. 19).

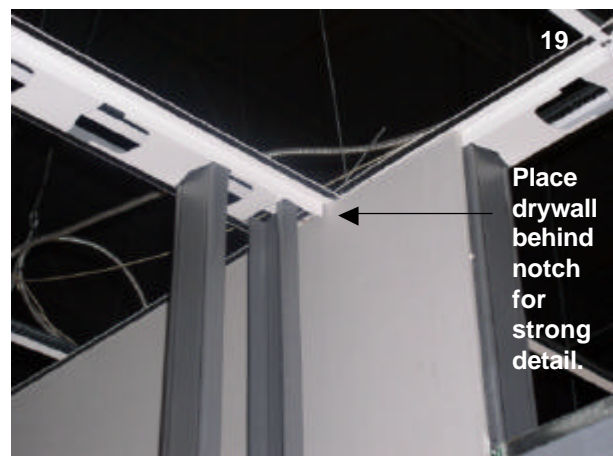

Eliminator Track™

Wall Studs



Once you have installed Eliminator Track™, putting the wall studs in place is as simple as inserting the stud through the pre-punched hole and snapping the stud into place



Eliminator TrackTM

Built by Pro Products Mfg., L.L.C.
32015 128th St. N.W. Princeton, MN 55371
(763) 552-0853 (O) (763) 552-0854 (F)